

TECHNOTES 7

A TECHNICAL SUPPLEMENT FROM BULLSEYE GLASS CO.

MONITORING KILN TEMPERATURES FOR SUCCESSFUL ANNEALING With a Multiple-Point Measuring System

When kilnforming glass, especially large-scale work, it is important to cool the glass uniformly throughout the annealing range. The temperature difference within the glass—from top to bottom, side to side, or end to end—should be no greater than 10°F (5°C). Such uniformity prevents a number of problems, including the creation of annealing strain, which can lead to glass failure.

At Bullseye, to ensure uniform cooling and proper annealing of large-scale work, we monitor temperatures at multiple points within the kiln during firing.

Our multiple-point temperature monitoring system involves the use of thermocouples and a pyrometer. The pyrometer displays temperatures that are sensed by the thermocouples, which are placed at two or more locations within the kiln. (Figure 1)

Information gathered and displayed by the pyrometer indicates how the glass and the kiln are heating and cooling and whether kiln temperatures need to be modified to prevent annealing strain—either by adjusting heat output from the top, bottom, or side elements (if they are controlled separately) or by slowing the cooling rate.

A multiple-point temperature monitoring system is well worth the small investment in equipment and energy required for installation. In this document, we discuss when to employ such a system, the equipment that is needed, where to find the equipment, how to install it, and how to use the information gathered to help ensure successful annealing.

WHEN TO USE A MULTIPLE-POINT TEMPERATURE MONITORING SYSTEM

There are two main reasons to use a multiple-point temperature monitoring system:

- To monitor a project's cooling rate throughout the annealing range
- To determine how well a kiln is firing.

Even a kiln that you have used for many years should be monitored with a multiple-point system because heating and cooling in such a kiln may not actually be uniform.

While it is advisable to monitor temperatures any time you are firing large-scale work, it is especially important to do so when firing:

- Thick glass
- Projects that may be difficult to cool uniformly, such as complex forms
- New types of work—with unfamiliar shapes, sizes, or mold materials
- Kilns that are new or new to you
- Kilns that have not been fired for a long time.

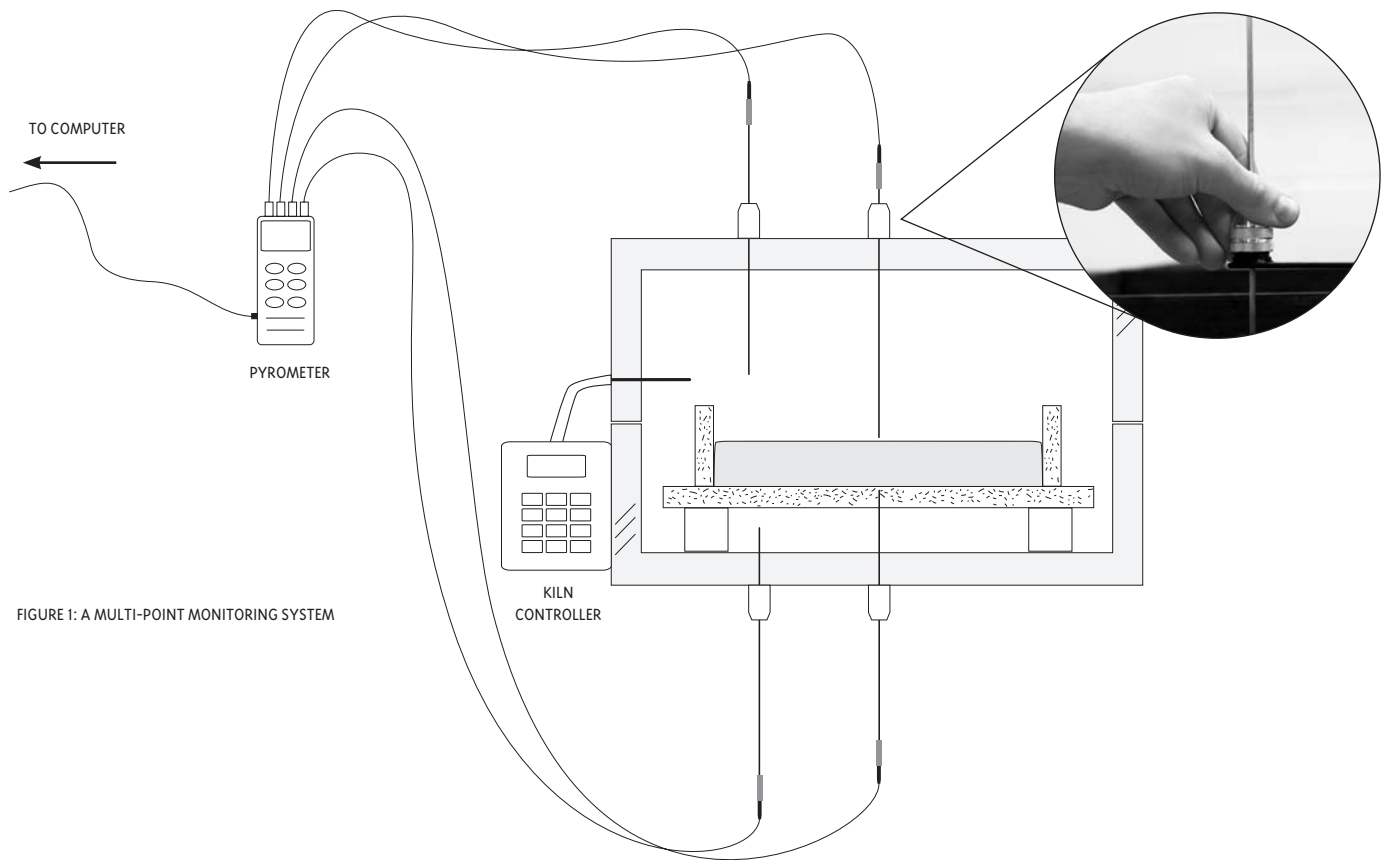

FIGURE 1: A MULTI-POINT MONITORING SYSTEM

To set up a multiple-point monitoring system, you will need:

- A 2 to 4 channel pyrometer
 - 2 to 4 thermocouples
 - 2 to 4 connectors
 - 2 to 4 mounted collets (keyless chucks)
 - Extension wire (in some setups, to connect thermocouples and pyrometer)
- (Models and vendors are recommended on page 3.)

HOW TO INSTALL THE EQUIPMENT

A pyrometer requires little installation. It can be either handheld or mounted to a convenient, flat surface. Thermocouples, however, must be positioned with considerable care to ensure readings that are both consistent and useful for each project being monitored.

Ensuring Thermocouple Consistency

It is critical that all thermocouples within any setup read temperatures to within 2°F (1°C) of each other. Most new thermocouples will read together as a group within this range. However, one malfunctioning thermocouple could render your entire monitoring system inaccurate; therefore, it is essential to test your thermocouples before installing them. Our simple testing procedure is described on page 5. Do not skip this necessary step.

Once determined to be reading together as a group, your thermocouples should provide consistent readings for many years, provided they are installed and cared for properly. Be sure to avoid the following situations, which can cause inconsistent readings:

- Loose connections (by far, the most frequent cause of problems)
- Damaged or kinked thermocouples
- Extension wire that is kinked, stretched, or spliced together
- Extension wire of different gauges within the group of thermocouples.

Where to Position Thermocouples Within the Kiln

Thermocouples should be positioned within the kiln to best serve the purpose of each firing—either to monitor the project’s cooling rate throughout the annealing range or to determine how well the kiln is firing.

To monitor the project’s cooling rate throughout the annealing range:

For large slabs of glass, we use a minimum of 2 thermocouples—one above and one below the top and bottom surfaces of the glass. (Figure 1) We position the bottom thermocouple by drilling a small hole in both the bottom of the kiln and the kiln shelf. Then we thread the thermocouple from underneath until it is as close as possible to the bottom surface of the glass without actually touching it. To position the top thermocouple, we drill a hole in the top of the kiln directly above the bottom thermocouple. During firing, when the glass has reached the anneal soak temperature, we loosen the collet and lower the top thermocouple down until it contacts the now-rigid glass surface. This thermocouple then allows us to accurately monitor the temperature of the top surface of the glass.

To determine how well the kiln is firing:

For this process, we typically place one thermocouple above the shelf at the same height as the kiln’s control thermocouple and one below the shelf. (Figure 1) Data collected at these points can help to determine how well the kiln is firing and whether or not the control thermocouple is reading accurately. This data can also be used to establish different programs for the top and the bottom of the kiln—if they can be independently controlled—to ensure a uniform temperature within the glass.

How to Position Thermocouples Within the Kiln

Positioning thermocouples within the kiln will require drilling small holes into the kiln, inserting the thermocouples, and securing them in place. Following is some general advice regarding these procedures.

When drilling into the kiln:

- Measure and mark before drilling.
- Be sure to avoid the element wires by centering the holes between them. Obviously, you do not want to damage the kiln’s element wires. You also do not want the thermocouples to contact element wires. If they do, you may experience electrical shock and damage the pyrometer and/or kiln.
- Standard drill bits will penetrate kiln brick and sheet metal.
- Drill the holes just large enough to accommodate the thermocouples.

TIP: Coat thermocouple tips with thickened shelf primer to prevent their sticking to glass.

To secure thermocouples in place:

- At Bullseye, we attach collets (keyless chucks, welded to small sheet metal plates) to the outside of the kiln, in line with the drilled holes. The collets can be hand-tightened and loosened to secure the thermocouples and/or reposition them, as needed. (Figure 1)
- Collets can be attached to the kiln either with clamps or self-tapping sheet-metal screws.

WHERE TO FIND EQUIPMENT FOR MULTIPLE-POINT TEMPERATURE MONITORING

At Bullseye, we buy our handheld pyrometers from Omega (www.omega.com). The Omega Web site has a configuration tool to help you purchase wires, connectors, and thermocouples to match the pyrometer you choose.

Omega sells a large range of pyrometers. We have used and can recommend these two simple models:

- The HH12A—a 2-channel digital thermometer. It has offset adjustment with recessed screws on the front panel, which is very convenient. This model offers no memory or PC connection, so you have to manually record the data during firing. (Price: about \$75, as of this printing.)
- The HH309—a four-channel data logger with internal memory to store readings while you are away, and the ability to interface with a PC running Windows by way of an RS232 connection. Software is included. (Price: about \$275, as of this printing.)

Depending upon the pyrometer model you select, you will need to buy either 2 or 4 thermocouples. (The thin-wire thermocouples that come with the pyrometers don’t last long.) Purchase thermocouples with these specifications:

- For compatibility, “ungrounded”
- Transition joint, “molded”
- Calibration, “K”
- Sheath material, “Inconel”
- Length, something that will reach the center of the kiln with a little room to spare
- Diameter, “1/8 inch”

You will also need connectors for plugging the thermocouples into the pyrometer. Buy one SMP-K-M (sub-mini connector) for each thermocouple. Depending on your setup, you may need to purchase extension-grade wire for the thermocouples.

To purchase pre-mounted collets, contact Paragon Industries (www.paragonweb.com).

HOW TO USE THE INFORMATION GATHERED

Some pyrometers can record information during firing. Recorded information can be read as data on the pyrometer or as a graph or table on a PC running Windows. (Figures 2 & 3) If your pyrometer cannot record data, you will have to record it manually during firing.

During the annealing phase of a firing, if the temperature difference between thermocouples monitoring the glass is more than 10°F (5°C), the kiln should be adjusted in one of the following two ways:

- If the kiln allows for separate control of elements in the top, side, or bottom zones, these temperatures should be adjusted until the difference is within 10°F (5°C).

OR

- If the kiln does not allow for separate control of zones, the cooling rate should be slowed until the temperature difference is within 10°F (5°C).

GENERAL INFORMATION ABOUT ANNEALING

If the cooling rates recommended in Bullseye's "Annealing Chart for Thick Slabs" (page 6) are used, and the temperature difference between top and bottom thermocouples is not greater than 10°F (5°C) during the anneal cooling stages, good annealing should result.¹

As noted on the annealing chart, the recommended firing cycles are "based on a flat slab of uniform thickness that is set up in such a fashion that it can cool equally from top and bottom." It is important to think not only about the thickness of the piece of glass, but also about how it is set up in the kiln. Are there insulating materials surrounding it, or under it, or anything else in the firing chamber with the glass that may impact how uniformly it may cool?

We have found that the best annealing for thicker works is achieved by insulating the perimeter of the glass with ceramic fiberboards, which are often used as dams. Because the perimeter of the work has more surface area per volume than the interior has, it will tend to cool off more rapidly. Insulating the perimeter prevents development of too large a temperature difference between the edges and the interior.

¹The Bullseye "Annealing Chart for Thick Slabs" was based on trials using a 3" thick block of glass with a thermocouple embedded in the middle, as well as two thermocouples touching the top and bottom of the glass respectively. These thermocouples exhibited less than a 10°F (5°C) temperature difference throughout the annealing range.



FIGURE 2: SOME PYROMETERS CAN RECORD DATA.

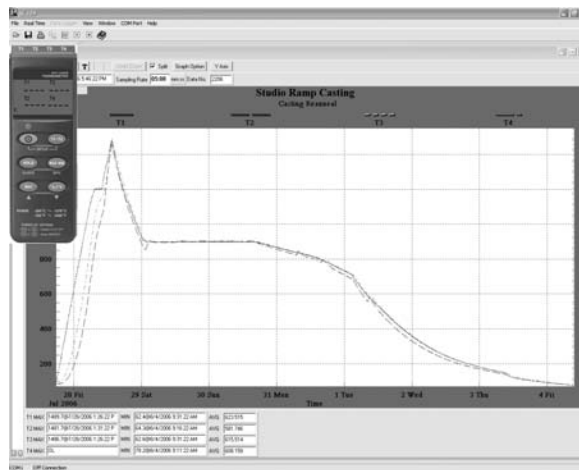

FIGURE 3: RECORDED DATA CAN BE DISPLAYED AS A GRAPH ON A PC RUNNING WINDOWS.

PROCEDURE FOR VERIFYING THAT THERMOCOUPLES READ THE SAME

In this procedure, you will insert the thermocouples into a kiln through the peephole; pack them into a partially hollowed length of iron or steel round stock (sometimes called a “core”) that is positioned in the center of the kiln; connect the pyrometer; fire the kiln; and adjust the thermocouple readings as necessary. When finished, you will remove the thermocouples from the metal core and transfer them and their extension wires (as assembled) to their working locations.

Follow these three steps:

1. Set up the core and thermocouples (TCs).
 - Set the metal core on a kiln post that is centered in the kiln.
 - Insert TCs through the peephole and into the hole in the metal core.
 - Pack both the core hole and the peephole tightly with fiber.
 - Plug TC extensions into the pyrometer and TCs.
 - Label TC & extension wire sets with the number of the input they are plugged into. (Figure 4)

Note: If preferred you can use a small kiln with a side or top peephole, such as a Paragon Caldera, for this entire procedure.

2. Program the kiln and fire.
 - Program the kiln to fire as fast as possible (AFAP) to the temperature at which you want the thermocouples to match (the anneal soak temp, for example) and program a hold for 4 hours.
 - Example program: AFAP to 960°F (516°C) for 4 hours.
 - Start the kiln.
3. Adjust the thermocouples to read the same.
 - Monitor the multiple-point display until the TCs have stabilized. This will take about 2+ hours.
 - Adjust the TCs to match TC1 by turning the offset adjustments on the pyrometer.
 - Do not adjust the TCs to match the kiln controller display temperature.
 - Turn off the kiln.

When the TCs are cool enough to handle, they can be pulled from the metal core and moved to their working locations. Be sure to keep the assembly as it is, with connectors and extension wires labeled, to ensure maximum accuracy in the working system.

To do this test, you will need:

- A pyrometer
- Two or more thermocouples (TCs) with all wire extensions and connectors to be used in the actual working setup
- A 2” (5cm) length of iron or steel round stock, 2” (5cm) in diameter, with a hole drilled halfway through. (Order from a machine shop for about \$25.)
- Ceramic-fiber-wool scraps
- A kiln post for supporting the round stock
- (Optional) A small kiln, like a Paragon Caldera, with a side or top peephole.

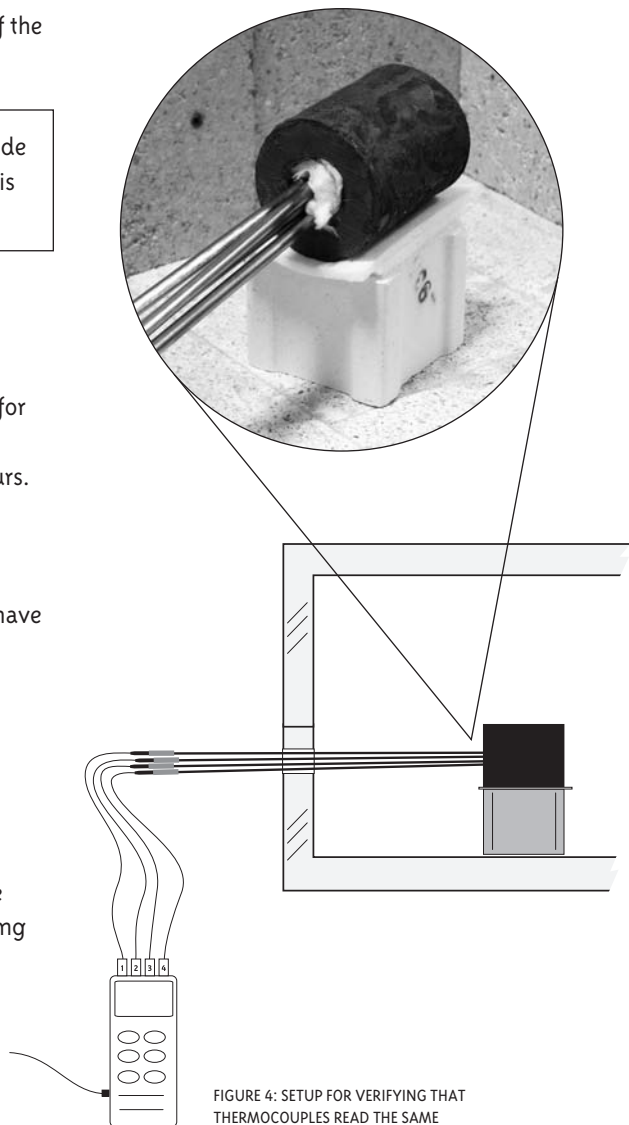

FIGURE 4: SETUP FOR VERIFYING THAT THERMOCOUPLES READ THE SAME

ANNEALING CHART FOR THICK SLABS

This annealing chart has been formulated for use with Bullseye clear glass. It is derived from Corning's method as shown in McLellan and Shand.* It is based on a flat slab of uniform thickness that is set up in such a fashion that it can cool equally from top and bottom. If the piece is not set up in such a fashion that it can cool equally from top and bottom or is anything besides a flat slab of uniform thickness, select an annealing cycle for a piece that is twice the thickness of the thickest area of the piece. Even a very conservative annealing cycle may not work if the kiln is not capable of cooling evenly. For more Bullseye technical and product information see www.bullseyeglass.com

THICKNESS	ANNEAL SOAK TIME	INITIAL COOLING RATE	INITIAL COOLING RANGE	2nd COOLING RATE	2nd COOLING RANGE	FINAL COOLING RATE	FINAL COOLING RANGE	TOTAL MINIMUM TIME
inches	@ 960 °F	°F/hr	°F	°F/hr	°F	°F/hr	°F	Hours
mm	@ 516 °C	°C/hr	°C	°C/hr	°C	°C/hr	°C	
0.5 in	2 hr	100	960 - 800	180	800 - 700	600	700 - 70	6 hr
12 mm		55	516 - 427	99	427 - 371	330	371 - 21	
0.75 in	3 hr	45	960 - 800	81	800 - 700	270	700 - 70	10 hr
19 mm		25	516 - 427	45	427 - 371	150	371 - 21	
1.0 in	4 hr	27	960 - 800	49	800 - 700	162	700 - 70	16 hr
25 mm		15	516 - 427	27	427 - 371	90	371 - 21	
1.5 in	6 hr	12	960 - 800	22	800 - 700	72	700 - 70	33 hr
38 mm		6.7	516 - 427	12	427 - 371	40	371 - 21	
2.0 in	8 hr	6.8	960 - 800	12	800 - 700	41	700 - 70	56 hr
50 mm		3.8	516 - 427	6.8	427 - 371	22	371 - 21	
2.5 in	10 hr	4.3	960 - 800	8	800 - 700	26	700 - 70	84 hr
62 mm		2.4	516 - 427	4.3	427 - 371	14.4	371 - 21	
3.0 in	12 hr	3	960 - 800	5.4	800 - 700	18	700 - 70	119 hr
75 mm		1.7	516 - 427	3.1	427 - 371	10	371 - 21	
4.0 in	16 hr	1.7	960 - 780	3.1	780 - 680	10	680 - 70	216 hr
100 mm		0.94	516 - 416	1.7	416 - 360	5.6	360 - 21	
6.0 in	24 hr	0.75	960 - 760	1.3	760 - 660	4.5	660 - 70	499 hr
150 mm		0.42	516 - 404	0.76	404 - 349	2.5	349 - 21	
8.0 in	32 hr	0.42	960 - 740	0.76	740 - 640	2.5	640 - 70	916 hr
200 mm		0.23	516 - 393	0.42	393 - 338	1.4	338 - 21	

* McLellan and Shand (1984), *Glass Engineering Handbook*, 3rd Edition, New York, McGraw Hill.